

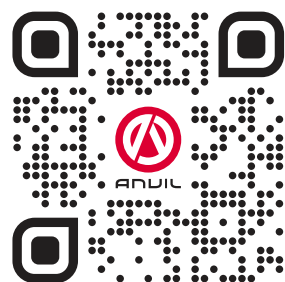

ANVIL

Installation, Operation and Care Manual



SCAN ME
TO GO TO
WARRANTY
REGISTRATION

MANUFACTURING
SINCE 1966

4-INS-PFE0800

THE CHEFS COMPANION

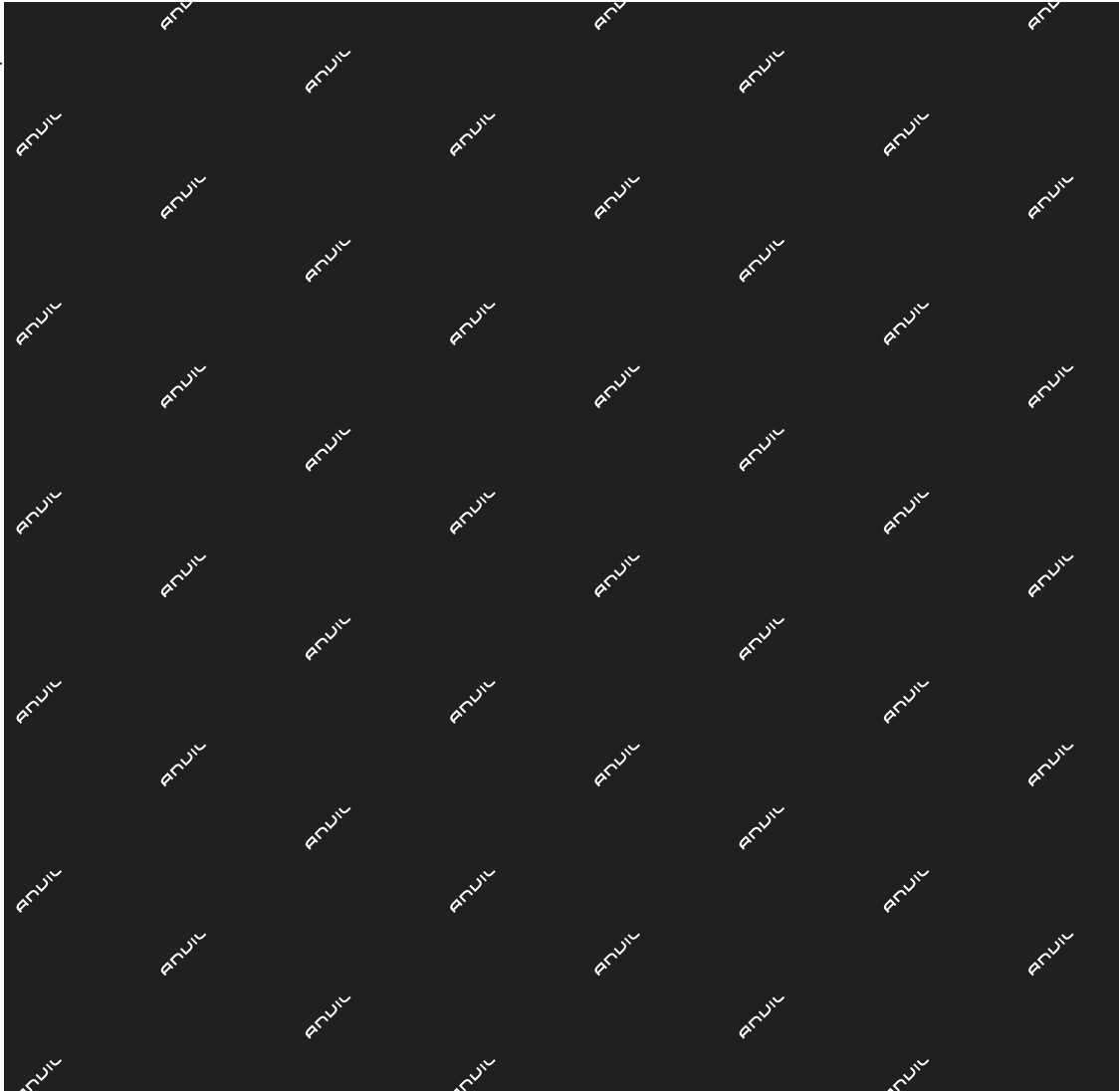

THE CHEFS COMPANION



THANK YOU FOR PURCHASING AN ANVIL PRODUCT!



REGISTER ONLINE TODAY

Register your warranty on-line at www.anvilworld.com today and learn how to get the best out of your Anvil product, tips to care for your Anvil product for long lasting performance, exciting recipes and more.

NO WEB ACCESS?

If you do not have access to the Web, register by completing this form and faxing it to the Anvil head office in South Africa. Fax: +27 11 474 1630

ONLY COMPLETE IF YOU DO NOT HAVE WEB ACCESS

Company _____

Name _____

Surname _____

Telephone _____

Cellphone _____

Email Address _____

Country _____

Postal address _____

Anvil products purchased _____

Code (see box label) _____

Serial number (see back of machine) _____

INTENDED USE

- Full-Service restaurant
- Coffee Shop / Deli
- Fast Food Outlet
- Hotel
- Bed & Breakfast
- School Cafeteria

- Institutional Cafeteria
- Corporate Catering
- Private Use
- Franchisor
- Convenience Store
- Other

 ALL ANVIL EQUIPMENT COMES WITH A TWO YEAR WARRANTY ON COMPONENTS AND DEFECTIVE WORKMANSHIP.

www.anvilworld.com

LIMITED WARRANTY

All equipment which is sold under ANVIL trademark and used for commercial purposes is warranted against defects in materials and workmanship. The warranty runs for one year from the date of original installation and is for the benefit of the original purchaser only. All other Warranties, expressed or implied, statutory or otherwise, including without limitations any implied Warranty of Merchantability or fitness for purpose are excluded. The Seller shall in no event be liable for direct, indirect or consequential damages in connection with ANVIL commercial products.

The Sellers obligation under this Warranty is limited to the repair of defects without charge. Defective units must be taken or shipped, transportation charges prepaid, to ANVIL.

This Warranty is not effective if damage occurs because of accident, carelessness, improper installation, lack of proper set-up, supervision when required or if the equipment is installed or operated in any manner contrary to the installation and operating instructions. In these cases, repairs will be made at a reasonable cost. Work performed by unauthorized personnel or unauthorized service agencies using non Anvil spares voids this Warranty.



NB:

REGISTER ON-LINE TODAY

Register your warranty on-line now at www.anvilworld.com

NO WEB ACCESS

If you do not have access to the Web. Kindly register by completing the warranty registration form and fax it to the ANVIL office in the country of purchase.

Failure to do so will invalidate your warranty.

4-INS-PFE0800 R01

25 LITRE ELECTRIC PRESSURE FRYER



**INSTALLATION OPERATION AND CARE OF
25 LITER ELECTRIC PRESSURE FRYER
MODEL: PFE0800**



ALL ANVIL EQUIPMENT COMES WITH A ONE
YEAR WARRANTY ON COMPONENTS AND
DEFECTIVE WORKMANSHIP.



www.anvilworld.com

UNPACKING

Unpack the product and check for any damage incurred during transit. This should be reported to the responsible carrier, railway or postal authority, and a request for a damage report should be made.



THESE INSTRUCTIONS MUST BE FOLLOWED FOR US TO GUARANTEE OUR FULL SUPPORT OF YOUR CLAIM FOR PROTECTING AGAINST LOSS FROM CONCEALED DAMAGE. THE FORM FOR FILING SUCH A CLAIM WILL BE PROVIDED BY THE CARRIER.

GENERAL INSTALLATION AND OPERATION INSTRUCTIONS

1. For the correct operation of this equipment carefully read the instructions and observe all the recommendations contained herein KEEP THE MANUAL FOR FUTURE REFERENCE.
2. The Installation of appliances may only be carried out by a registered installer and such installations shall comply with the local regulatory requirements
3. Remove plastic material protecting the stainless steel panels.
4. Unit must be installed on a fire proof floor; if floor is of wood, arrangement must be made to comply with local fire department regulations. Rear of unit must be at least 100mm from the wall. If unit is closer, the wall must be fire proof.
5. Position unit: Check with spirit level, use floor adjusters on legs to bring to correct level.
6. The appliance should be installed in a ventilated place with an air extraction canopy.
7. The electrical connection must only be done by a suitably qualified technician or trained person.
8. This fryer is provided with Locking castors please turn the wheels horizontal and lock when the machine is positioned.
9. Check the exhaust valve and insure the puck inside can move up and down freely
10. Fill the tank insert with the correct volume of cooking oil. Ensure that the oil level is not higher than the Max oil level mark. The oil level should always cover the temperature probe.

EXPLODE VIEW 25 LITER ELECTRIC PRESSURE FRYER MODEL: PFE0800

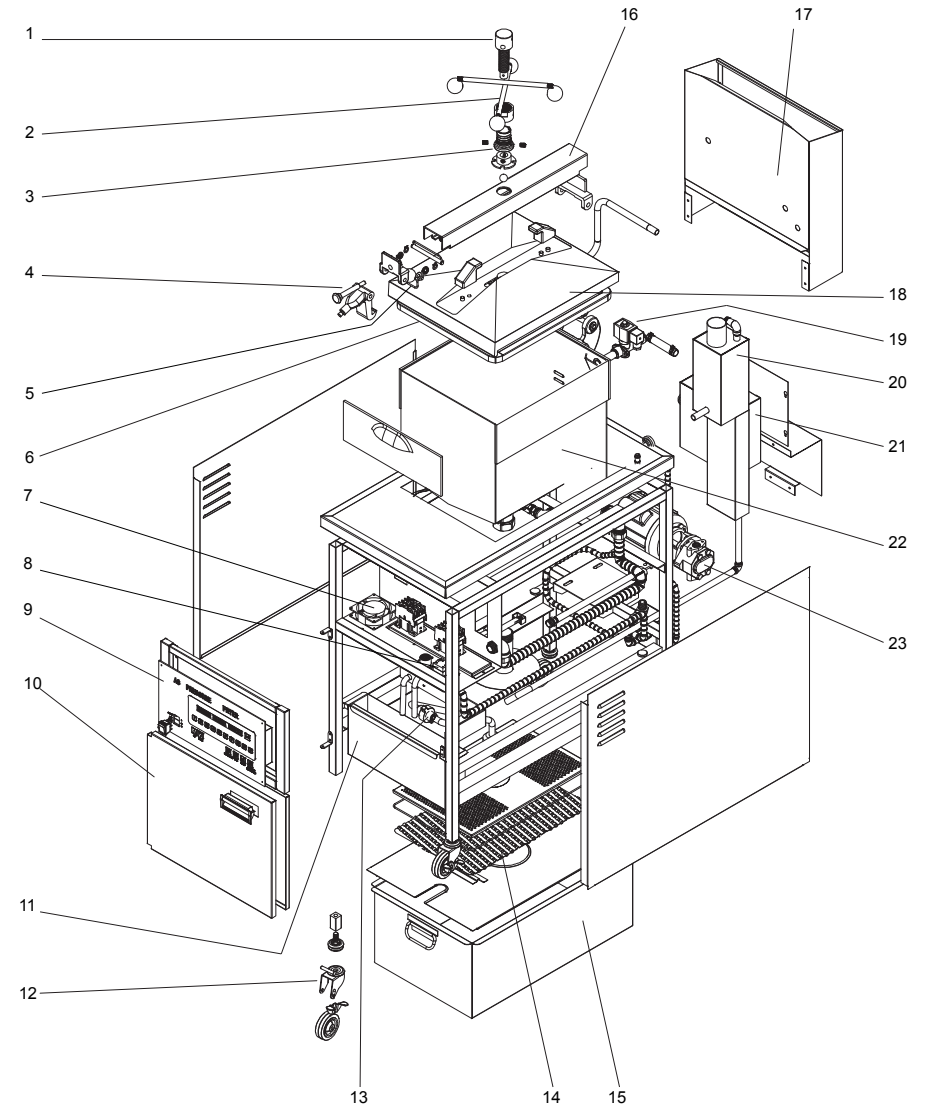

PRESSURE FRYER ELECTRIC
MODEL CODE : PFE0800

Part No.	Description
1	TIGHTENING SCREW
2	TIGHTENING HANDLE
3	NUT & BOLT ASSEMBLY
4	HANDLE HOOK
5	SPRING FOR HOOK LOCK
6	SEAL
7	FAN
8	OVER TEMPERATURE THERMOSTAT
9	CONTROL PANEL FASCIA
10	DOOR
11	WATER TANK
12	CASTOR WHEEL ASSEMBLY
13	OUTLET TUBE
14	FILTER PAPER
15	OIL TANK
16	BEAM
17	EXHAUST FLUE
18	LID
19	SOLENOID VALVE
20	STEAM SEPARATOR
21	SWITCH BOX
22	FRY TANK
23	OIL PUMP
24	TEMPERATURE PROBE
25	DRAIN TAP
26	OIL PUMP TAP
27	MICRO SWITCH
28	BASKET
29	VENT VALVE
30	SAFETY VALVE
31	PRESSURE METER
32	SPRING

11. Do not overfill the basket and carefully load the product into the hot oil. A danger of surge boiling can occur if the food to be fried is excessively wet or if the frying basket is too full.
12. Install an automatic fire extinguisher over the fryer and in the exhaust duct. Never direct such extinguishers so as to blow the oil out of the container

CONTROL PANEL LAYOUT

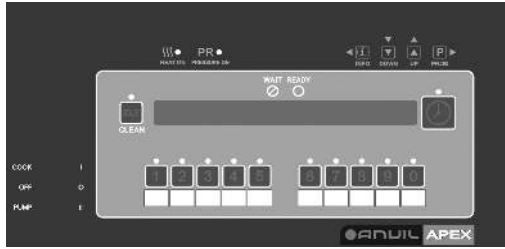

OPERATING CONTROLS OVERVIEW

digital display	Shows the oil temperature, the timer countdown in the Cook Cycle, and the selections in the Program Mode; the temperature of the oil can be shown by pressing once, or twice to view set-point temperature; if oil temperature exceeds 425°F (218°C), the display reads "E-5, FRYER TOO HOT"
READY	This LED lights when the oil temperature is within 5° of the setpoint temperature, signaling the operator that the oil temperature is now at the proper temperature for dropping product into the frypot
[Clock icon]	The timer buttons are used to start and stop Cook Cycles
IDLE	The idle buttons are used to start an Idle Mode which reduces the temperature of the oil during non-use periods; press and hold to exit the Idle Mode
P	The program button is used to access the Program Modes; also, once in the Program Mode, it is used to advance to the next parameter
[Up/Down arrow icons]	Used to adjust the value of the currently displayed setting in the Program Mode and to change set-point temperature of the oil.

LINE DRAWING 25 LITER ELECTRIC PRESSURE FRYER MODEL: PFE0800

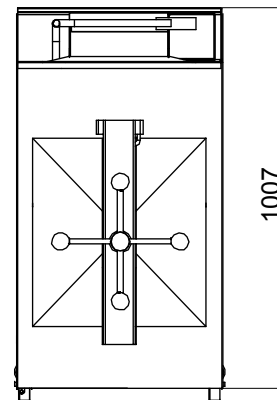
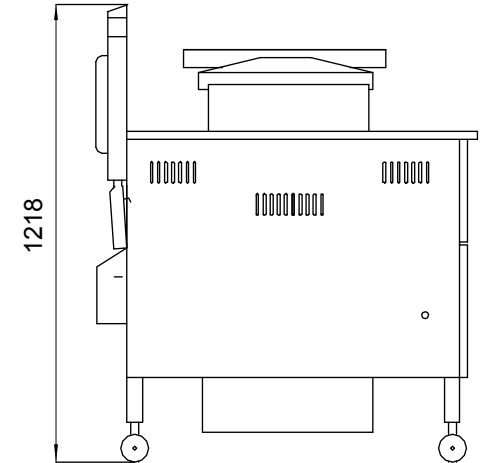
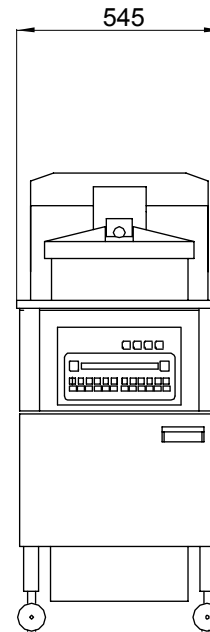

- Replace the crumb catcher screen on top of the filter paper. Screw on the suction standpipe assembly.
- Place complete filter screen assembly back into filter drain pan and slide pan back into place beneath the fryer.
- Connect the filter union by hand. Do not use a wrench to tighten.
- Slide the condensation drain pan back into place. The fryer is now ready to operate.

CHANGING THE CHARCOAL FILTER (OPTIONAL):

The charcoal filter should be changed every day or whenever it becomes clogged with crumbs. Proceed as follows:

- Move the main power switch to the OFF position.
- Remove and empty the condensation drain pan.
- Disconnect the filter union and remove the filter drain pan from beneath the frypot.
- Discard oil, or pump shortening back into frypot.
- Wearing protective gloves or using a cloth, remove the charcoal filter assembly from drain pan.
- Place charcoal filter assembly on a counter or table, turn the 4 clips securing the charcoal pad frame, and pull frame from assembly.
- Remove and discard old filter pad. Clean and dry pan, frame, and grid thoroughly.
- Place grid, frame and new charcoal filter pad in assembly with smooth side facing the grid and secure with clips.
- Slide the drain pan back into place under the fryer and connect the filter union by hand. Do not use a wrench to tighten.
- Slide the condensation drain pan back into place. The fryer is now ready to operate.

OPERATION DIGITAL CONTROL

The MAIN SWITCH is located on the left side of the panel. In the "OFF" position there is no display on the control panel. In the "PUMP" position the display will show "pump". In the "Cook" position The display will light up all indicators and display "888888888888" while it calibrates.

The display will prompt "IS POT FILLED" the operator must respond by pressing either key 1 for YES or key 2 for NO.

If there is no oil in the pot and key 2 is pressed The display will show "TURN OFF UNTIL FILLED" The operator must turn the main switch to the off position.

OIL DISSOLVING MODE

On start up the machine will automatically default to melting mode and display "MELT 41°C" . The unit is programmed to allow the oil or lard to dissolve slowly and safely. The temperature displayed is the actual oil temperature.

When the temperature has reached 110°C the operator may exit this mode by pressing any of the numbered programme buttons. The display will prompt the operator "EXIT MELT?" "1-YES 2-NO" The operator can press 1 to exit melting mode.

CLEAN MODE

During melting mode if the IDLE button is pressed the unit will go into Clean mode and display "CLEAN 40°C 10:00" the unit will heat the oil to 40°C and then start counting down 10 minutes. After 10 minutes has past The display will show "CLEAN DONE" turn off the machine to exit this programme.

FRY MODE

The fry time, temperature and pressure are precisely monitored for each fry programme. One fry programme can be divided into 10 phases. Pressure and temperature can be set for each phase.

IDLE MODE

At any time the fryer may be deployed to " IDLE " mode by pressing the idle button. The idle temperature is pre programmed, see *presets* section. The unit can be programmed to enter into idle mode after current timing cycle or after melting mode.

OIL FILTRATION LOCK

After the preset number of fry cycles has been reached the Display will show " FILTER LOCK 125°C" The temperature will be maintained at 125°C and the display will show "PLEASE OPEN OIL VALVE" The operator is required to open the oil filtration valve to start the oil filtration process.

INQUIRY

At any time the INFO button can be pressed and will display:

1. Current Oil Temperature in Pot " - xxx °C-"
2. Set temperature "SETPT = xx °C"
3. Oil Filtration Counts "FILTER 2 REMAIN"
4. Time and date.

ERROR AND ALARM CODES

Index	Display	Translation
1	E-6A	Sensor reading failure
2	E-5	Oil overheated
3	Change Oil	Oil Change over alarm
4	E-15	Oil Discharge Valve open

PROGRAMMING PRODUCT PARAMETERS

Pressing "P" button for 1 second opens the product program mode. Product parameter mode sets 10 parameters per product. Password has to be entered before setting, default password is "123" Scroll through the settings using the arrow keys to increase and decrease values using



up down keys

FILTER PUMP PROBLEM PREVENTION

The following steps will help prevent filter pump problems:

- Make certain the charcoal filter is installed with the smooth side down and the arms on the frame are clamped down over the protrusions on the outside of the frame.
- The filter valve is to be closed at all times during frying.
- Pump all the oil from the filter lines by running the filter pump motor until the oil in the frypot appears to be bubbling or boiling.

CHANGING THE FILTER ENVELOPE

The filter envelope should be changed after 10-12 filterings or when-ever it becomes clogged with crumbs. Proceed as follows:

- Move the main power switch to the OFF position.
- Remove and empty the condensation drain pan.
- Disconnect the filter union and remove the drain pan from under the frypot. If available, a drain pan may have casters under it, allowing easy transport of filter pan and filter assembly.
- Lift the screen assembly from the drain pan.
- Wipe the oil and crumbs from the drain pan. Clean the drain pan with soap and water, then thoroughly rinse with hot water.
- Unscrew the suction standpipe from the screen assembly.
- Remove the crumb catcher and clean thoroughly with soap and water. Rinse thoroughly with hot water.
- Remove the filter clips and discard the filter envelope.
- Clean the top and bottom filter screen with soap and water. Rinse thoroughly with hot water.
- Be sure that the filter screens, crumb catcher, filter clips, and the suction standpipe are thoroughly dry before assembly of filter envelope as water will dissolve the filter paper.
- Assemble the top filter screen to the bottom filter screen.
- Slide the screens into a clean filter envelope.
- Clamp the envelope in place with the two filter retaining clips.

TROUBLESHOOTING GUIDE

Problem	Cause	Correction
Power switch ON but fryer completely inoperative	Open Circuit	Fryer plugged in Check breaker or fuse at wall
Pressure not exhausting at end of cook cycle	Solenoid or Exhaust line clogged	Turn OFF and allow fryer to cool to release the pressure in frypot; have all lines, solenoid, and exhaust tank cleaned
Operating pressure too high	Deadweight clogged	Turn OFF and allow fryer to cool to release the pressure in frypot; clean deadweight
Pressure does not build up	Not enough product in frypot Faulty PC board Lid gasket leaking	Place full capacity product in frypot when using fresh oil Have controls checked by service technician, Reverse or replace lid gasket
Oil not heating	Gas valve knob turned to the OFF position Drain valve open High temperature limit tripped	Make sure gas control valve knob is turned to the ON position Close drain valve Reset high temperature limit
Oil not draining	Drain valve clogged	Push cleaning rod through open drain valve
Filter motor won't run	Motor overheated	Reset motor protector

PROGRAMMING PRODUCT PARAMETERS

TABLE OF PARAMETER OPTIONS FOR EACH PROGRAMME

Code	Function
NAME	Enter Name of product
PRE LOAD	Pre heating time, (1st stage temperature)
1 TIME AT	Total amount of time, maximum 59m:59s
1 TEMP	Set temperature of 1st stage
1 PRESSURE	Selected pressure of 1st stage
2 TIME AT	Note: the time duration of 2nd stage must be shorter than the total time length, the time length of 3rd stage must be shorter than the 2nd stage time.
2 TEMP	Set temperature of 1st stage...etc 10 stages can be set
ALARM-1	Set Alarm time (4 time sets in Total)
	Set Alarm Method (5 types of alarm in Total)
QUAL TIME	Set quality time
LOAD COMP	Set Load compensation strength
LCOMP REF	Set reference temperature compensation point
IDLE MODE	Set whether or not to enter into idle mode when operation time ends
FILTER INC	GLOBAL, FILTER INCL, MIXED, FILTER AFTER

PROGRAMMING SPECIAL PARAMETERS

Pressing "P" button for 5 seconds opens the LEVEL 2 program mode.

TABLE OF PARAMETER OPTIONS FOR EACH PROGRAMME

Code	Function
SP-1	Setting temperature mode (°F or °C)
SP-2	System initialization, Press down button and hold to launch System initialization.
SP-3	Select Oil Melt Mode, 1-Liquid, 2-Solid. Heating starts for 12 seconds and then stops for 12 seconds. For Liquid setting, heating starts for 2 seconds and then stops for 14 seconds when temperature is below 80°C.

PROGRAMMING SPECIAL PARAMETERS

Pressing "P" button for 5 seconds opens the LEVEL 2 program mode.

TABLE OF PARAMETER OPTIONS FOR EACH PROGRAMME

Code	Function
SP-4	Use Idle mode, no parameter when "NO" is selected
SP-4A	Setting Idle heating temperature from 90~190°C
SP-4B	Setting auto idle time OFF~60min, Off shows no auto idle time
SP-4C	Idle mode after melting
SP-5	3 filtration alarm modes 1-OFF 1-OFF = NO Oil filtration alarm and locking 2-MIXED 2-MIXED= Filtration threshold is set upon different product grade 3-GLOBAL 3-GLOBAL=common and unified filtration threshold 1-OFF 1-OFF = no parameter when "1-OFF" is selected.
SP-5A	2-MIXED (75~100%) FOR 2-MIXED, oil filtration percentage alarm (75~100%)
SP-5B	lock oil filtration
SP-5C	2-MIXED (100~200%) For 2-MIXED, oil filtration percentage (100~200%) 3-GLOBAL (120~190°C) For 3-GLOBAL, Filtration temperature (120~190°C)
SP-5D	2-MIXED (120~190°C) Parameter for 2-MIXED, Filtration Temperature (120~190°C)
SP-6	Select Timing start mode, 1-COOK, 2-SELECT. In cook mode start by pressing "product" button, timing button won't start operation cycle. In select mode, "product" button only selects products, must use "timing" button to start cycle
SP-7	Select clean time, OFF~99min In OFF no cleaning cycle.

DESCRIPTION OF MODEL

MODEL	DESCRIPTION	POWER (Watts)	VOLTAGE
PFE0800	25 LITER ELECTRIC PRESSURE FRYER	13 500W	400V

**LINE DRAWING
25 LITER ELECTRIC PRESSURE FRYER
MODEL: APF0800**

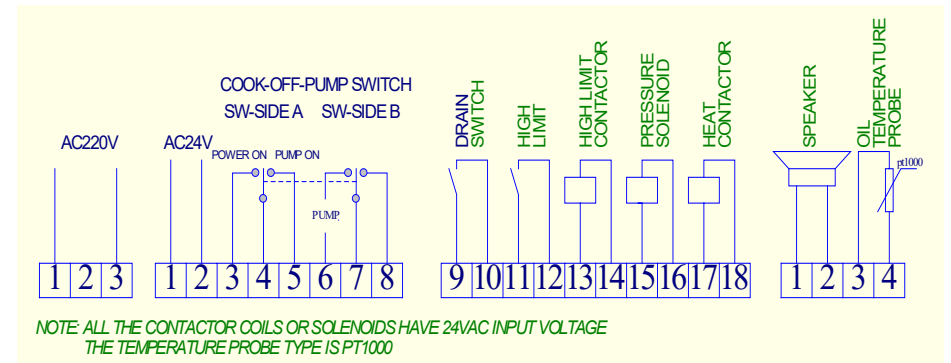

SAFETY CONTINUED.

3. Do not use an appliance that is damaged, leaking or which does not operate properly.
4. Ensure that the assembled unit is stable and does not rock.
5. Do not cover or change the primary air supply apertures in the burner as this will affect the performance of the product and may lead to unstable flames.
6. Do not modify the appliance or use it for anything other than what it has been designed for.
7. During use, part of the appliance will become hot, particularly the cooking areas and top. Avoid touching hot parts with your bare hands. The use of oven gloves is recommended.
8. Keep young children away from the appliance at all times.
9. Fill the tank insert with the correct volume of cooking oil.
10. Ensure that the oil level is at the engraved MIN marking inside the tank. Do not overfill unit.
11. Do not overfill the basket and carefully load the product into the hot oil. A danger of surge boiling can occur if the food to be fried is excessively wet or if the frying basket is too full.
12. Install an automatic fire extinguisher over the fryer and in the exhaust duct. Never direct such extinguishers so as to blow the oil out of the container
13. A danger of fire exists if the oil level is below the minimum indicated level.
14. Keep areas and filters clean above the fryer – oil soaked lint or dust can ignite easily and flames will spread rapidly.
15. It is dangerous to use old oil as this can reduce the flash point and cause surge boiling.
16. Hot oil is flammable: keep open flames away from it and its vapors. Do not leave unit in operation without an attendant.
17. Never allow a water jet into the hot oil, it can explode!!!!

PROGRAMMING SPECIAL PARAMETERS

Pressing "P" button for 5 seconds opens the LEVEL 2 program mode.

TABLE OF PARAMETER OPTIONS FOR EACH PROGRAMME

Code	Function
SP-8	Set Clean temperature (40~90°C)
SP-9	Oil change alarm, Max 5000 cycles, Reminder for Oil change when heating cycles counts to the number or above. "OFF" disables
SP-10	Oil change alarm, Max 999hr, Reminder for Oil change when heating hours counts to the number or above. "OFF" disables
SP-11	Setting Parameter setting password.
SP-11	Change oil change password.

PROGRAMMING SPECIAL PARAMETERS

Pressing "P" button in LEVEL 2 program mode enters into (1) SP PROG which is used for setting time and date settings.

TABLE OF PARAMETER OPTIONS FOR EACH PROGRAMME

Code	Function
CS-1	Setting Year
CS-2	Setting Month
CS-3	Setting day
CS-4	Setting Weekdays
CS-5	Setting Hours
CS-6	Setting Minute

The blinking data of year, month, hour and minute shows the current data. Code for Months are as follows: JAN-1, FEB-2, MAR-3, etc. Codes for weekdays are : MON-, TUE-, WED-, THU-, FRI-, SAT-, SUN-

REVIEW USAGE SETTING

Pressing "P" and ⓘ button together opens the "REVIEW USAGE" Interface. Press "P" to cycle through each parameter until "RESET_USG" Interface is reached. "oil change over and reset password" enter password (default 123) to reset history parameter of oil change, note date and start counting at zero. Pressing "P" and ⓘ button together to exit the interface

TABLE OF PARAMETERS AVAILABLE

Content	Function
REVIEW USAGE SINCE NOV-14	Displays date of last oil change and reset.
POWER ON HRS 6	Displays how many hours the power has been on.
TOTAL CK 20	Displays the total of timed frying cycles.
OIL WEAR 'A' 40%	Displays the oil wear percentage calculated using total cycles of timed frying.
OIL WEAR 'B' 20%	Displays the oil wear percentage calculated using total hours of power on.
USAGE_____	Reset PW of oil change over, If PW is correct -USAGE RESET- displays.

Intervals	Maintenance Function
Routine Daily Actions:	<ul style="list-style-type: none"> • Check the deadweight valve for functionality. • Execute end-of-day closing routines
Inspections Every Week:	<ul style="list-style-type: none"> • Assess the condition of the optional rinse hose for any deterioration.
On-Demand Services:	<ul style="list-style-type: none"> • Manually activate the reset for the filter pump motor protector. • Remove debris from the optional crumb tray as needed. • Preemptively troubleshoot filter pump issues. • Replace the shortening based on usage. • Refresh the filter envelope regularly.
Prior to Changing Shortening:	<ul style="list-style-type: none"> • Thoroughly cleanse the frypot.
Maintenance Every Quarter:	<ul style="list-style-type: none"> • Flip the lid gasket to ensure even wear. • Apply lubricant to the lid for smooth operation. • Make adjustments to the limit stop for proper function. • Ensure all spreader bars are securely fastened.
Annual Check:	<ul style="list-style-type: none"> • Service the safety relief valve

SAFETY

READ ALL INSTRUCTIONS BEFORE USE. FAILURE TO FOLLOW THESE PRECAUTIONS COULD RESULT IN INJURY TO YOURSELF AND OTHERS

1. When this fryer is to be positioned in close proximity to a wall, partitions, kitchen furniture, decorative finishes, etc. it is recommended that they be made of non-combustible material.
2. If not, they shall be clad with a suitable non-combustible heat insulating material, and the closest attention be paid to fire prevention regulations.

- Wash down and scrub the sides of the frypot.
- After the sides and bottom are cleaned, open the drain valve.
- Rinse the frypot interior. Especially work on hard to clean areas, like the frypot bottom.
- After sufficient rinsing with oil, close the drain valve.
- Pump all the oil out of the filter pan and back into the frypot. Close lid during first surge of pumping.
- When the pump is pumping air only, the oil in the frypot will appear to be boiling. Close the filter valve first and then move the main power switch from PUMP to OFF. This will keep the filter pump and lines from filling up with oil.
- After completing the filtering operation, empty and replace the condensation drain pan.



WARNING

Burn Hazard.

Do not touch hot food, liquid or heating surfaces while equipment is heating or operating

Hot surfaces and food can burn skin. Allow the hot surfaces to cool before handling

CLEANING AND MAINTENANCE



1. There are no predetermined maintenance intervals for this appliance. It is dangerous to use an appliance with a cracked or perished seal and/or hose. Inspect both seals and hose regulator and replace if they are not in order, before using the appliance.
2. If the appliance was in use, it will be hot. Allow to cool sufficiently before attempting any maintenance.
3. Remove large pieces of food residue from the oil, carefully skim surface.
4. Wash all exterior and interior surfaces with hot soapy water solution. DO NOT use harsh abrasives on any portion of the stainless or coated surfaces.

OPERATING INSTRUCTIONS

- Check to see that all control switches are off and the drain and filter valves are in the closed position. (diagram 1 page 9)
- Remove the basket from the frypot and leave lid open.
- Make sure frypot is filled with oil to the proper level.
- Make sure electrical power is connected to fryer.
- Display shows "OFF" until power switch is turned to the ON position. Display now shows the cook time and the unit automatically goes into the Melt Cycle until the oil temperature reaches 230°F (110°C). The control then automatically exits the Melt Cycle.
- The Melt Cycle may be bypassed, if desired, by pressing and holding  for 3 seconds.
- Once out of the Melt Cycle, the oil is heated until lights and the cook time is displayed.
- Using the basket handle, thoroughly stir oil to stabilize the temperature throughout the frypot.
- Once the oil temperature has stabilized at the setpoint temperature, lower the basket into the frypot.
- Knock off any excess breading and place the breaded product on a tray for cooler storage. Place a damp cloth over the breaded food to retain moisture. The breaded food should be held for a minimum of 30 minutes before frying so that it can absorb spices from the breading and so that breading can better adhere to the product.
- Determine the time and temperature settings according to the type of product to be fried.
- Set the controls to the desired temperature and time. See Programming Instructions Section.
- Place the food into the submerged basket by first putting in the largest pieces (thighs and drumsticks). This gives the large and more difficult pieces time to fry a few extra seconds. Leave the lid open.

- Lift the basket slightly out of the oil and shake it, causing the pieces to separate. Return the basket to the oil. Doing this will prevent white spots on the finished product.
- Remove the basket handle and close the lid quickly. Latch the lid with the lid latch.
- Tighten the lid spindle clockwise to properly secure and seal the lid. Align the red knob on the spindle with the red knob on the lid latch.



- Press  or product button
- Within a few minutes, the pressure gauge should increase to the OPERATING ZONE. If it does not recheck the procedures.
- Make sure the pressure gauge indicator needle reads in the Operating Zone. A full load must be placed in frypot upon using new oil, or not enough steam will be generated to obtain full cooking pressure.
- At the end of the Cook Cycle (the timer reaches zero), the fryer automatically depressurizes, the timer buzzer sounds, and the display flashes "DONE". Press  button to turn off alarm.
- After the pressure drops to zero, turn the spindle counterclockwise approximately one turn.
- Raise the lid promptly to allow most of the condensation on the lid to drain down and out through the drain channel and not back into the oil.

DO NOT LIFT HANDLE OR FORCE LID LATCH OPEN BEFORE PRESSURE GAUGE READS "0" PSI. ESCAPING STEAM AND SHORTENING WILL RESULT IN SEVERE BURNS !

- To avoid damage to the hinge, do not let the lid slam up against its backstop.
- Insert the handle into the basket. Lift the basket and hang it on the side of the frypot to drain. Allow the product to drain approximately 15 seconds before dumping it onto a tray.
- Place the product into a warming cabinet immediately
- Before frying the next load, wait until  is on, indicating the oil has reheated.

FILTERING INSTRUCTIONS

- Turn the main power switch to the OFF position. Remove and clean the fry basket in soap and water. Rinse thoroughly.
- The best results are obtained when the oil is filtered at the normal frying temperature.
- Use a metal spatula to scrape any build-up from the sides of the frypot. Do not scrape the curved portion of the frypot.

Scraping the curved portion of the frypot, produces scratches in these surfaces causing breading to stick and burn.

- Do not bang the pot scraper, or other cleaning utensils, on the frypot rim. Damage to the frypot rim could result and the lid may not seal properly during a cook cycle.
- Open the drain valve very slowly, half a turn at first and then slowly to the full open position. This will prevent excessive splashing of the hot oil as it drains into the filter drain pan.
- When all of the oil has drained, scrape or brush the sides and the bottom of the frypot.

Rinse the frypot as follows:

- Close the drain valve. Open the filter valve. Lower lid and hold closed.
- Move the main power switch to the PUMP position. Carefully open the lid to see if the oil is returning properly. Fill frypot 1/3 full, then turn off pump.

FAILURE TO HOLD THE LID CLOSED SO THAT THE FIRST SURGE OF THE RETURNING OIL WILL NOT SPLASH OUT OF THE FRYPOT, WILL RESULT IN SEVERE BURNS.