



# Vacuum Pack Machine

Instruction manual



**Model:  
DK208-A**

## Safety Instructions

- Position on a flat, stable surface.
- A service agent/qualified technician should carry out installation and any repairs if required. Do not remove any components on this product.
- Consult Local and National Standards to comply with the following:
  - Health and Safety at Work Legislation
  - Fire Precautions
  - Wiring Regulations
  - Building Regulations
- DO NOT immerse the appliance in water.
- The sealing bar becomes hot during use. DO NOT touch the sealing bar during or immediately after operation.
- Do not turn Off at the plug to halt operation; always use the **ON/OFF** button.
- Do not use the appliance for anything other than its intended use.
- Only use bags recommended by the supplier/manufacturer with the appliance.
- Always switch off and disconnect the power supply to the appliance when not in use.
- Not suitable for outdoor use.
- Keep all packaging away from children. Dispose of the packaging in accordance to the regulations of local authorities.
- If the power cord is damaged, it must be replaced by an APURO agent or a recommended qualified technician in order to avoid a hazard.
- Children should be supervised to ensure that they do not play with the appliance.

- This appliance is not intended for use by persons (including children) with reduced physical, sensory or mental capabilities, or lack of experience or knowledge, unless they have been given supervision or instruction concerning the use of the appliance by a person responsible for their safety.
- APURO recommend that this appliance should be periodically tested (at least annually) by a Competent Person. Testing should include, but not be limited to: Visual Inspection, Polarity Test, Earth Continuity, Insulation Continuity and Functional Testing.

## Introduction

Please take a few moments to carefully read through this manual. Correct maintenance and operation of this machine will provide the best possible performance from your APURO product.

## Pack Contents

The following is included:

- APURO Vacuum Pack Machine
- Sealing bar
- Instruction manual

APURO prides itself on quality and service, ensuring that at the time of unpacking the contents are supplied fully functional and free of damage.

Should you find any damage as a result of transit, please contact your APURO dealer immediately.

## Location of Controls

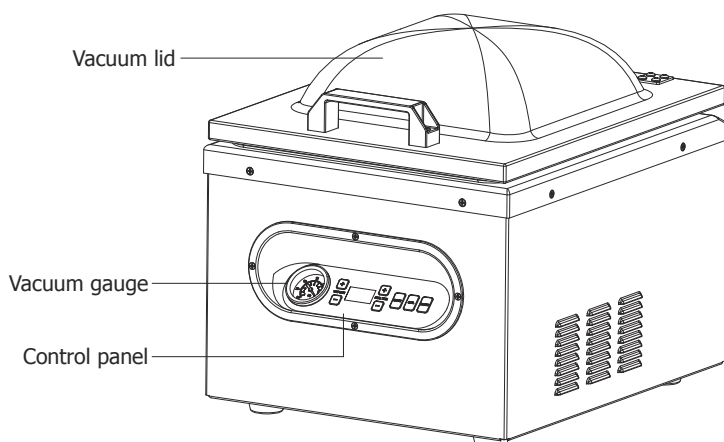

## Controls

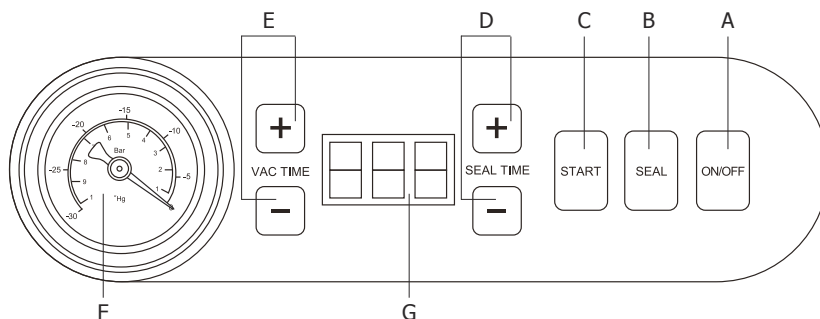

### A. On/Off Button (On/Off)

- After the machine is plugged in, LED display (G) will show "Off". Press the On/Off button, LED display (G) will show "On". Now the machine is ready to use.
- After using the machine, press the On/Off button before unplugging the machine.
- During use, pressing the On/Off button will stop the machine.

### B. Seal Button (Seal)

Press the "Seal" button to stop the vacuum cycle and instantly seal the bag to prevent crushing delicate items.

### C. Auto Vacuum Start Button (Start)

After closing the lid, press "Start" button. The machine will vacuum and seal automatically.

### D. Seal Time Adjusting Button (Seal Time "+" or "-")

Simply adjust the seal time "up" or "down" by using "+" or "-" buttons.

### E. Vacuum Time Adjusting Button (Vac Time "+" or "-")

Simply adjust the vacuum time "up" or "down" by using "+" or "-" buttons.

### F. Vacuum Gauge

Shows the vacuum level inside the vacuum chamber.

### G. LED Display

Shows the vacuum/seal time.

## Operation

Plug in Vacuum Pack Machine and turn on Power Switch. The machine is now ready for use.

### Vacuum Packing Food

1. Place the food inside in the bag.
2. Allow minimum of 25mm-50mm of space at the top of bag to ensure a good seal.
3. Place the open end of the bag across the sealing bar. Close lid.
4. Press the Start button.
5. The machine goes to vacuum cycle. When vacuuming, vacuum time setting will be shown on the Digital Display and count down from default setting to 0.

**Note: Vacuum time setting is adjustable from 5-60 (6.25-75 seconds). Default setting is 30 (37.5 seconds).**

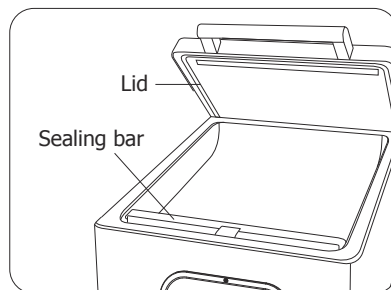

6. At anytime during vacuum cycle pressing the Seal button will override timer and complete the vacuuming and sealing cycle.
7. After the vacuum process the machine automatically goes to sealing cycle.
8. When sealing, seal time setting will be shown on the Digital Display and count down from default setting to 0. **Note: Seal time setting is adjustable from 3-9 (1.8-5.4 seconds). Default setting is 8 (4.8 seconds).**
9. Take out the bag and check the vacuum and seal. (Note: A good seal will look clear upon inspection. If the seal is spotty, incomplete, wrinkled, white or milky, remove sealed portion and run vacuum and seal process again.)
10. Press "ON/OFF" button to stop the machine at any time.

**Please store the vacuumed items properly. All perishable foods must be refrigerated or frozen to prevent spoilage.**

## Cleaning, Care & Maintenance



**Always allow to cool before cleaning.**

**WARNING: Do not allow any water to spill into the appliance when cleaning.**

- Use warm, soapy water and a damp cloth to clean the appliance.
- Dry thoroughly after cleaning.

## Troubleshooting

A qualified technician must carry out repairs if required.

Fault	Probable Cause	Solution
The appliance is not working	The unit is not switched on	Check unit is plugged in correctly and switched on
	Plug or lead is damaged	Replace plug or lead
	Mains power supply fault	Check mains power supply
Appliance does not remove all the air from the bag	Bag not correctly positioned	Open lid and reposition bag
	Open end of bag is dirty	Clean bag
	Bag may be punctured	Replace bag
	Incorrect bags used	Call Vacuum Pack machine supplier
Bags are not sealing correctly	Moisture in bag under the sealing bar	Ensure inside of the bag is dry and free from moisture where it is to be sealed
	Incorrect bags used	Call Vacuum Pack machine supplier
	End of bag not placed above sealing bar	Move end of bag over sealing bar
	Heat sealing foam bar missing or incorrectly aligned	Replace or re-position
	Sealing Bar requires replacement	Consult a qualified technician
	Sealing bar/lid seal is dirty	Clean sealing bar/lid seal

Fault	Probable Cause	Solution
"CLO" on display	Unit in protection mode	Open the lid, then the unit will return to normal operation
Error message E01 in Digital Display	The lid is open while the machine is in heating mode	Close the lid. If the error code persists, there may be something wrong with the micro switch, thus Call APURO agent or qualified technician
NOTE: Sealing bar replacement is not covered under warranty		

## Technical Specifications

Note: Due to our continuous improvement process, the product specifications are subject to change without notice.

Model	Voltage	Power	Current	Vacuum Pressure (approx.)	Dimensions h x w x d mm	Weight (kg)
DK208-A	220-240V~ 50Hz	630W	2.7A	-992mbar	366 x 359 x 425	22.3

## Electrical Wiring

The plug is to be connected to a suitable mains socket.

This appliance is wired as follows:

- Live wire (coloured brown) to terminal marked L
- Neutral wire (coloured blue) to terminal marked N
- Earth wire (coloured green/yellow) to terminal marked E

This appliance must be earthed.

If in doubt consult a qualified electrician.



Electrical isolation points must be kept clear of any obstructions. In the event of any emergency disconnection being required they must be readily accessible.

## Compliance

The product must not be disposed of as household waste. To help prevent possible harm to human health and/or the environment, the product must be disposed of in an approved and environmentally safe recycling process. For further information on how to dispose of this product correctly, contact the product supplier, or the local authority responsible for waste disposal in your area.

Apuro parts have undergone strict product testing in order to comply with regulatory standards and specifications set by international, independent, and federal authorities.

Apuro products have been approved to carry the following symbol:



**All rights reserved. No part of these instructions may be produced or transmitted in any form or by any means, electronic, mechanical, photocopying, recording or otherwise, without the prior written permission of APURO. Every effort is made to ensure all details are correct at the time of going to press, however, APURO reserve the right to change specifications without notice.**

# DECLARATION OF CONFORMITY

- Conformiteitsverklaring • Déclaration de conformité • Konformitätserklärung • Dichiarazione di conformità •
- Declaración de conformidad • Declaração de conformidade

Equipment Type • Uitrustingstype • Type d'équipement • Gerätetyp • Tipo di apparecchiatura • Tipo de equipo	Model • Modèle • Modell • Modello • Modelo
Chamber Vacuum Pack Machine	DK208-A
Application of Territory Legislation & Council Directives(s) Toepassing van Europese Richtlijn(en) • Application de la/des directive(s) du Conseil • Anwendbare EU-Richtlinie(n) • Applicazione delle Direttive • Aplicación de la(s) directiva(s) del consejo	<b>Electrical Safety</b> IEC 60335-1:2010+A1: 2013+A2: 2016 IEC 60335-2-45:2002+A1: 2008+A2: 2011  <b>Electro-Magnetic Compatibility (EMC)</b> EN IEC 55014-1: 2021 EN IEC 55014-2: 2021 EN IEC 61000-3-2: 2019+A1: 2021 EN 61000-3-3: 2013+A1: 2019+A2: 2021
Manufacturer Name • Naam fabrikant • Nom du fabricant • Name des Herstellers • Nome del fabbricante • Nombre del fabricante	Apuro

I, the undersigned, hereby declare that the equipment specified above conforms to the above Territory Legislation, Directive(s) and Standard(s).

Ik, de ondergetekende, verklaar hierbij dat de hierboven gespecificeerde uitrusting goedgekeurd is volgens de bovenstaande Richtlijn(en) en Standaard(en).

Je soussigné, confirme la conformité de l'équipement cité dans la présente à la / aux Directive(s) et Norme(s) ci-dessus  
Ich, der/die Unterzeichnende, erkläre hiermit, dass das oben angegebene Gerät der/den oben angeführten Richtlinie(n) und Norm(en) entspricht.

Il sottoscritto dichiara che l'apparecchiatura di sopra specificata è conforme alle Direttive e agli Standard sopra riportati.

El abajo firmante declara por la presente que el equipo arriba especificado está en conformidad con la(s) directiva(s) y estándar(es) arriba mencionadas.

Date • Data • Date • Datum • Data  
• Fecha

Signature • Handtekening • Signature  
• Unterschrift Firma • Firma

Full Name • Volledige naam • Nom et prénom • Vollständiger Name  
• Nome completo • Nombre completo

Position • Functie • Fonction • Position  
• Qualifica • Posición

Manufacturer Address • Adres fabrikant • Adresse du fabricant • Adresse des Herstellers • Indirizzo del fabbricante • Dirección del fabricante

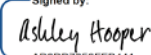
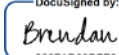
23 <sup>th</sup> Apr 2025	
Signed by:  AB6DB7656FFB441...	DocuSigned by:  386FAD00DFE8483...
Ashley Hooper	Brendan Denmeade
Group Head of Product Quality & Compliance	Commercial Manager/ Responsible Supplier
Fourth Way, Avonmouth, Bristol, BS11 8TB United Kingdom	15 Badgally Road, Campbelltown NSW 2560



**apuro**

DK208-A\_A5\_v2\_2025/04/28