

CC506 1.5m Round Folding Table

Instruction manual

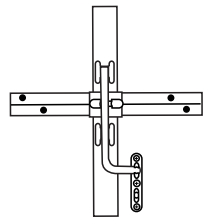

**Model:
CC506**

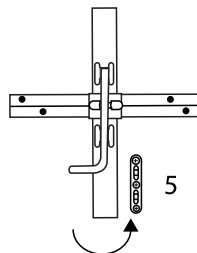
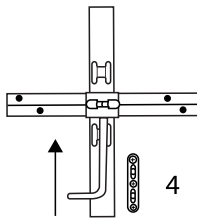
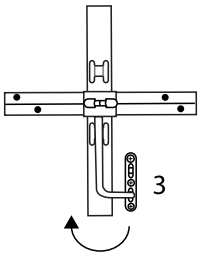
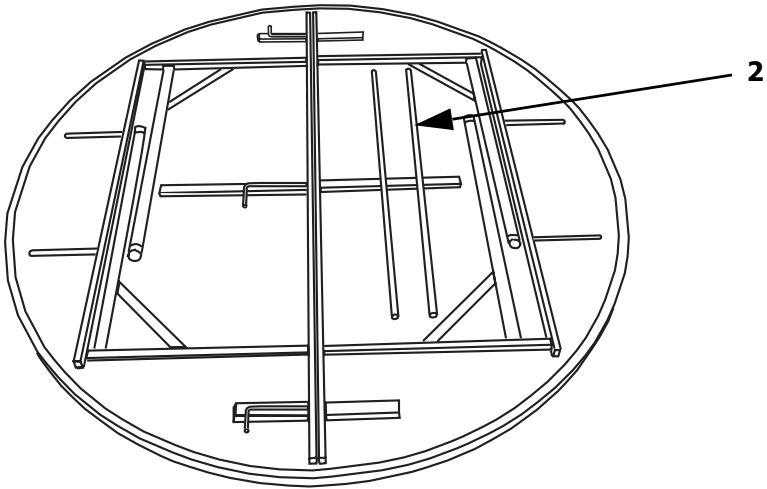
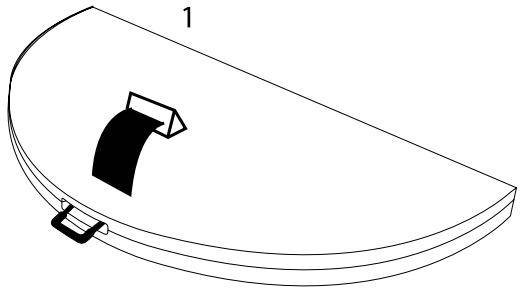

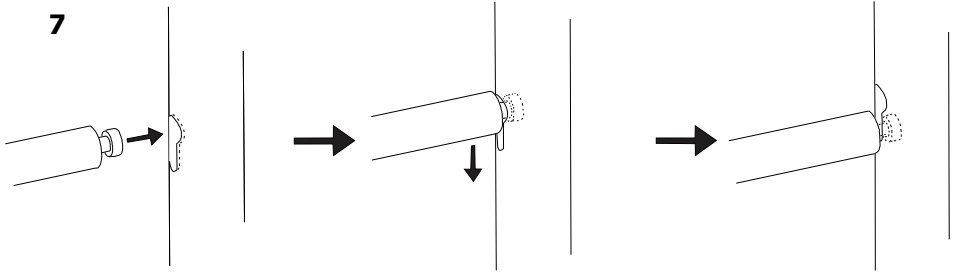
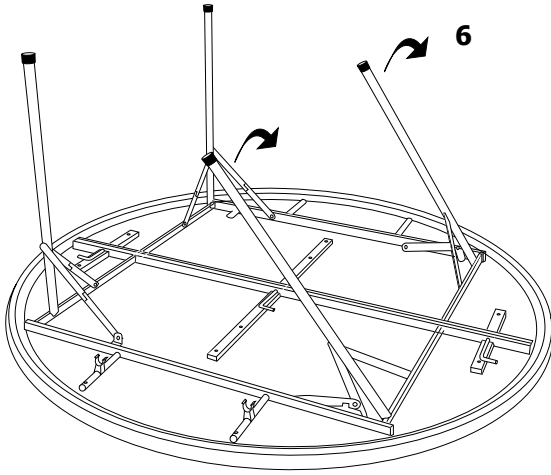

Safety Tips

- Do not overload the table top causing it to bend. Max. Load Weight (evenly spread): 125 kgs.
- Do not place heavy weights on the table edge.
- Do not stand on the table top.
- Always ensure the table is securely closed when folding up and storing/transporting.
- Store table on its end when not in use.

Assembly

1. Place the folding table upside down on a flat surface.
2. Unfold the table [1].
3. Remove both bars from the underside of the table [2].
4. Free the support pin [3] from the underside of the table, push it through the central support [4] and press back into the underside of the table [5]. Repeat for the second and third pins.

i **NOTE: Whether in the open or closed position, ensure the support pin handles are securely located back in the underside of the table to stop them from working free.**

5. Lift up the legs [6]
6. Turn the table upright.
7. Slot the bars into the legs [7].

i **NOTE: Closing the table is a reverse of the above procedure. Ensure the handle is outside the table when closing for ease of transportation.**

• Notes •

• Notes •

• Notes •
